



*LA Techniques Ltd*

---

## LA19-13-04 6 GHz Vector Network Analyser

### Overview and Data Sheet



The LA19-13-04 is a USB controlled Vector Network Analyser capable of providing professional performance and capability at an unprecedented level of affordability. The instrument uses a four receiver architecture allowing support for 8 error terms calibration techniques in addition to traditional 12 error terms correction.

The LA19-13-04 uses a highly integrated design in order to provide a uniquely affordable solution which nevertheless boasts exceptional performance such as close to 118 dB of dynamic range, 0.005 dB rms trace noise at its maximum operating bandwidth of 140 kHz, a maximum measurement speed of 190  $\mu$ s per point for all 4 s-parameters and 10 Hz frequency setting resolution. All of this in a compact package with a footprint of 29 cm x 17 cm.

The LA19-13-04 can be supported by most commercially available calibration kits as well, of course, as LA Technique's precision PC3.5 calibration kits. These are TRL referred kits that offer outstanding precision at modest cost.

### Take anywhere professional performance

- 300 kHz to 6 GHz Operation
- Fast speed of 190  $\mu$ s per frequency point for all 4 s-parameters measurement
- Four receiver architecture supports 12 and 8 error term calibration methods
- Up to 118 dB of dynamic range with 10 Hz operating bandwidth
- Trace noise of 0.005 dB rms at its maximum operating bandwidth of 140 kHz
- Time domain transmission and reflectometry
- Network de-embedding and reference plane extension.

## Four receiver architecture

At the centre of the instrument is a four receiver architecture.. This approach is more complex than traditional three or even two receiver arrangements but has the benefit that the imperfections of the forward / reverse switch can be removed mathematically. This in turn allows 8-term calibration methods such as the ‘unknown thru’ to be implemented.

The forward / reverse switch has been designed to achieve very fast settling times so that both forward and reverse measurements can be taken at every frequency point tuned by the signal synthesizers. Some competing instruments require two frequency sweeps as the switch is too slow, taking tens of milliseconds to settle.

The hardware implementation provides sweep trigger signals to allow synchronised measurements to be carried out. Another feature of the hardware is the provision of bias-Ts which provide a means of powering up active devices under test.

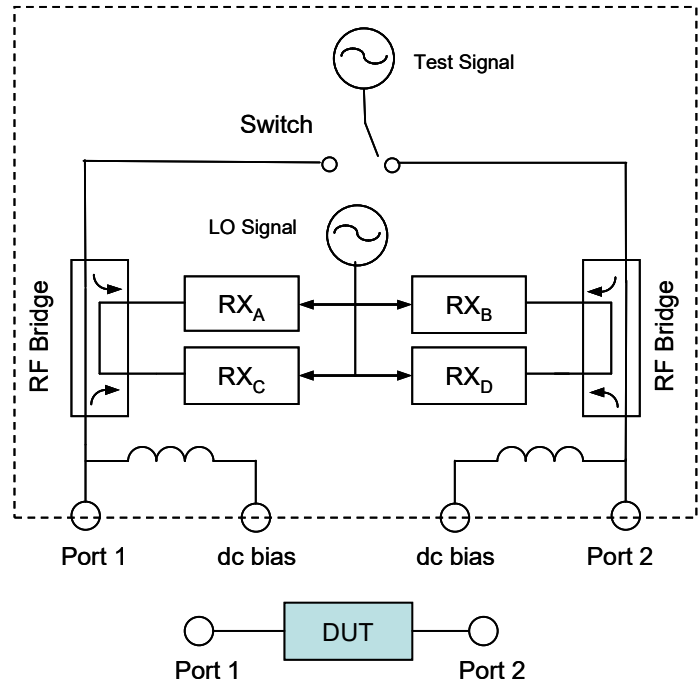

## Precision calibration kits

Precision PC3.5 calibration kits are available as optional accessories. These kits are data based. That means that each of the standards (Short, Open, Load and Thru) is defined by measured data rather than the more traditional approach of model parameters. The advantage of measured data is of lower cost but without sacrificing accuracy.

Each of the standards is characterised over the range 1 MHz to 6 GHz in two bands. From 1 MHz to 1.5 GHz they are measured using a reference VNA with a commercial precision calibration kit and SOLT (Short/Open/Load/Thru) calibration. Above 1.5 GHz a TRL calibration is employed to carry out very accurate measurements referred to a precision air line. A further refinement is the application of post-measurement processing to remove systematic errors introduced by small variations of the characteristic impedance of the air line associated with effects of skin depth, particularly at the lower microwave frequencies.



## Comprehensive and easy to use software

The user interface software was developed by experienced users of VNAs with ease of use being the key driver. The main tasks such as calibration, display set up and measured data saving are simple and straightforward to carry out.

The combination of professional grade performance, small size, weight and cost make the LA19-13-04 ideal for a range of applications including research and development, production, field service, installation test, and classroom applications. With its support for remote automation, the LA19-13-04 is also ideal for ATE applications. With respect to production testing, there is the ability to set up limit lines with up to 11 segments over the measurement band for limit line testing. Visual and audio limit fail alarms are provided.

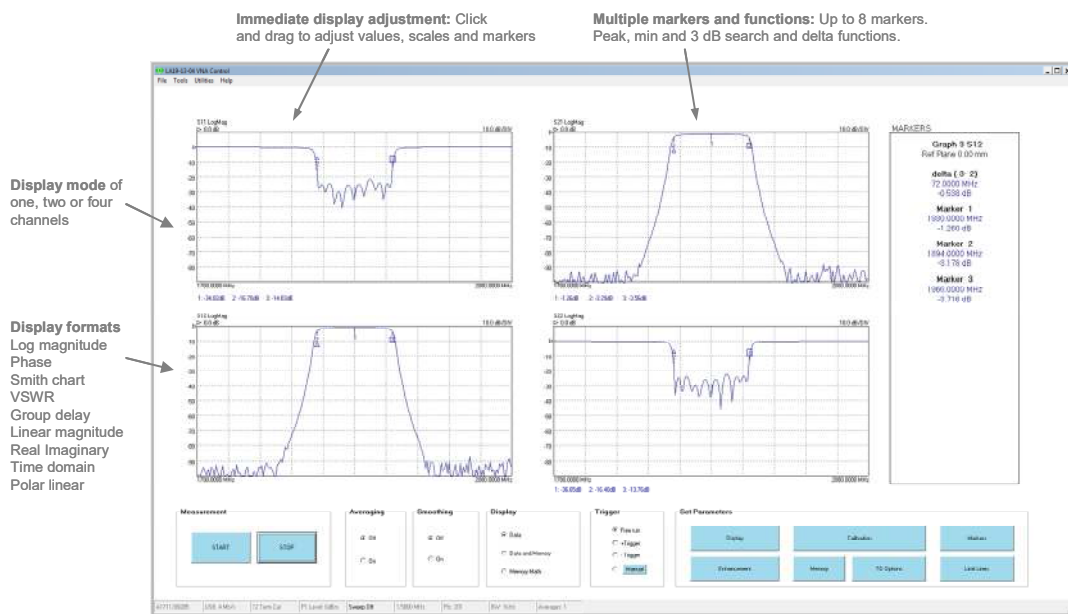

Reference plane extension (manual and automatic) together with network de-embedding provide very useful aids to measurement of, for example, surface mount components.

Support for Unknown Thru calibration, an efficient method for measuring devices which are not 'insertable', for example, typical evaluation boards fitted with female SMA connectors at both ends.

LA Techniques have been designing and manufacturing USB driven VNAs for close to 20 years and all versions of the software have included a simple to use calibration kit editor. The editor with the LA19-13-04 allows for very quick creation of calibration kits from either model data or measured data. This versatility allows kits to be created for most commercially available calibration kits. Using the editor, the user can also quickly create "clone" kits from precision kits using low cost parts.

Other useful utilities include Data Compare (compares measured data with reference data loaded from disk), P1dB gain compression measurement, AM to PM conversion measurement and a signal generator function.

## Specification

The instrument's specification is given below. Unless otherwise stated, the figures apply with a 10Hz resolution bandwidth, at -3dBm test power with no averaging and no interpolation and at an ambient temperature of between 20°C and 30°C but within 1°C of the calibration temperature and 60 minutes after power up. Where applicable, the figures apply to the use of LA's calibration kits DW97157 and DW97158 or better precision kits.

### Receiver Characteristics

Measurement Bandwidth (Hz):  
 140 k, 70 k, 35 k, 15 k, 10 k, 5 k,  
 1 k, 500, 100, 50, 10

**Average displayed noise floor**, dB below the test signal level set to maximum power after an S21 calibration with ports terminated as during the isolation calibration step

Band (MHz)	Typical	Max
0.3 - 10	-110	-100
10 - 4000	-118	-108
> 4000	-110	-100

**Dynamic Range**, with 10Hz bandwidth, +6 dBm test power and no averaging: see graph (typical, excludes crosstalk)

**Temperature stability**, measured after an S21 calibration, typical:

- 0.02 dB/°C for  $F < 4$  GHz
- 0.04 dB/°C for  $F \geq 4$  GHz

**Trace noise, dB rms**, measured using a 201 points sweep covering 1 MHz to 6 GHz and test power set to 0 dBm

Bandwidth	Typical	Max
10 kHz	0.0008	0.002
70 kHz	0.003	0.005
140 kHz	0.005	0.01

### Measurement Uncertainty

In addition to the conditions outlined earlier in this section, the figures apply for a 12 error term calibration (insertable device) carried out with a good quality 3.5 mm calibration kit capable of achieving the performance specified.

#### Reflection measurements

Range	Magnitude	Phase
-15 dB to 0 dB		
Freq < 2MHz	0.7	8°
Freq > 2MHz	0.5	4°
-25 dB to -15 dB		
Freq < 2MHz	0.8	10°
Freq > 2MHz	1.0	6°
-30 dB to -25 dB		
Freq < 2MHz	3.0	20°
Freq > 2MHz	2.5	15°

#### Transmission measurements

Range	Magnitude	Phase
+0 dBm to +6 dBm		
Freq < 2MHz	0.4	6°
Freq > 2MHz	0.2	2°
-40 dBm to 0 dBm		
Freq < 2MHz	0.2	2°
Freq > 2MHz	0.1	1°
-60 dBm to -40 dBm		
Freq < 2MHz	0.5	8°
Freq > 2MHz	0.3	4°
-80 dBm to -60 dBm		
Freq < 2MHz	2.0	15°
Freq > 2MHz	1.5	12°

## Spurious responses

The main spurious response occurs at close to  $(2 \times RF + 1.3)$  MHz, where RF is the test frequency in MHz. For example, when testing a band-pass filter with a centre frequency of, say 1900 MHz, then an unwanted response will occur around 949.35 MHz. There may also be spurious responses close to  $(3 \times RF + 2.6)$  MHz. In all known cases the levels will be as follows:

-76 dBc typical, -70 dBc max

## Dynamic range

Test signal level set to maximum, the IF bandwidth set to 10 Hz and a sweep plan of 201 points.

Dynamic range 0.3 MHz to 10 MHz

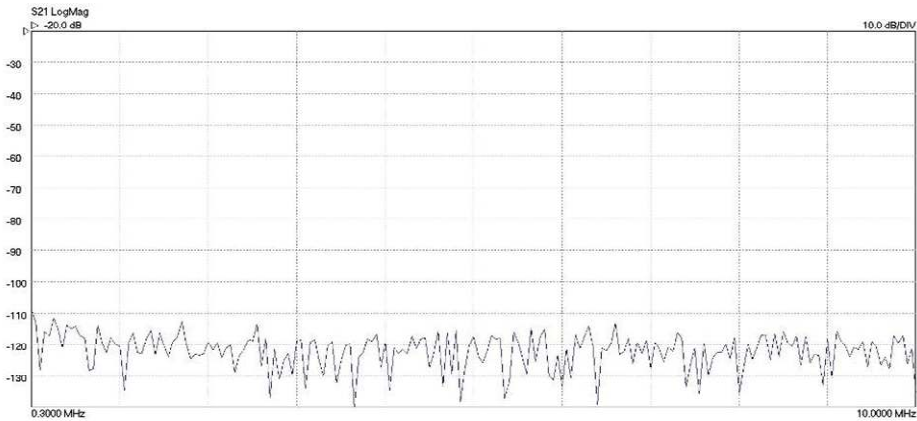

Dynamic range 10 MHz to 6 GHz

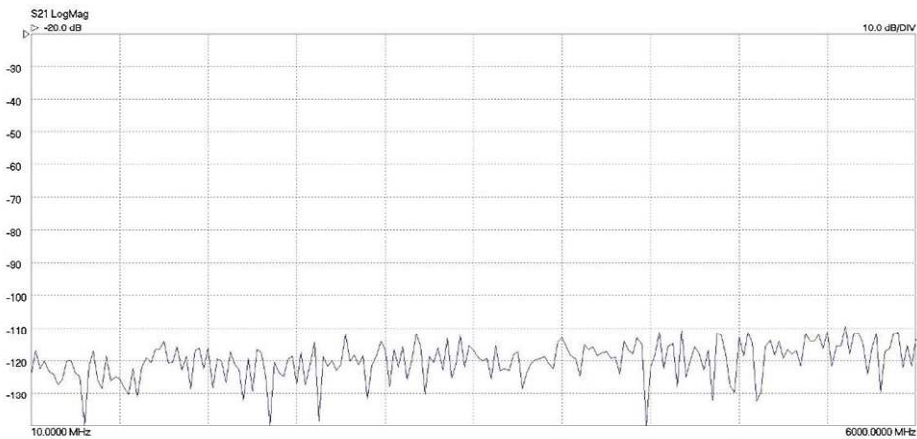

## Test port characteristics

### Load match

Uncorrected: 16 dB, typical  
 Corrected: 46 dB, typical  
 40 dB, min

### Source match

Uncorrected: 16 dB, typical  
 Corrected: 46 dB, typical  
 40 dB, min

### Directivity

Corrected: 47 dB, typical  
 40 dB, min

### Crosstalk

Corrected, measured with both calibrated ports terminated in short circuits after isolation calibration

Band	Typical	Max
< 2 MHz	-100	-90
2 MHz – 4 GHz	-110	-90
4 GHz – 6 GHz	-100	-90

### Maximum input level

1 dB compression: +10 dBm, typ

### Maximum input level

No damage: +23 dBm

## Measuring functions

### Measuring parameters

S11, S21, S22, S12  
 P1dB, 1dB gain compression  
 AM-PM conversion factor

### Error correction

12 error term full s-parameter correction (insertable DUT)

12 error term full s-parameter correction (non-insertable DUT using calibrated thru adaptor)

8 error term full s-parameter unknown thru adaptor correction (non-insertable DUT)

S11 (1 port correction)

### Test port connectors

Type N, female

### Bias-T maximum current

250 mA (7.5Ω path resistance, typ)

### Bias-T maximum dc voltage

±25 V

### Bias-T current protection

Built-in resettable fuse

### Bias-T dc port connectors

SMB

### Sweep trigger output voltage

Low: 0 V to 0.8 V  
 High: 2.2 V to 3.6 V

### Sweep trigger input voltage

Low: -0.1 V to 1 V  
 High: 2.0 V to 4 V

### Sweep trigger input voltage

No damage: ±6 V

### Sweep trigger in/out connectors

BNC, female on back panel

de-embed (2 embedding networks may be specified), impedance conversion

S21 (normalise, normalise + isolation)

S21 (source match correction + normalise + isolation)

Averaging, smoothing,

Hanning and Kaiser Bessel filtering on time domain measurements,

electrical length compensation (manual),

electrical length compensation (auto),

effective dielectric constant correction,

### Display channels

4 channels

### Traces

2 traces per display channel

### Display formats

Amplitude (logarithmic and linear)  
Phase, Group Delay, VSWR, Real,  
Imaginary, Smith Chart, Polar, Time  
Domain

### Memory trace

One per display channel

### Limit lines

6 segments per channel (overlap allowed)

### Markers

8 markers

### Marker functions

Normal,  $\Delta$  marker, fixed marker, peak /  
min hold, 3 dB and 6 dB bandwidth

### Sweep functions

#### Sweep type

Linear sweep  
CW sweep (timed sweep)  
Power sweep (P1dB utility)

#### Sweep times

140 kHz bandwidth  
10 MHz to 6 GHz sweep  
201 points (12-term cal): 37 ms  
201 points (S21 cal): 25 ms

#### Number of sweep points

51, 101, 201, 401, 801, 1024, 2001, 4001,  
9001, 10001

## Signal Source Characteristics

### Frequency range:

300 kHz to 6.001 GHz

### Frequency setting resolution:

10 Hz

### Frequency accuracy:

with ambient of  $23 \pm 3$  °C  
10 ppm max

### Frequency temperature stability:

$\pm 0.5$  ppm/°C max over the range  
 $+15$  °C to  $+35$  °C

### Harmonics:

With test power set to  $< -3$  dBm  
 $-20$  dBc max

### Non-harmonic spurious:

$-40$  dBc typical

### Phase noise (10 kHz offset):

$-90$  dBc/Hz [0.3 MHz to 1 GHz]  
 $-80$  dBc/Hz [1 GHz to 4 GHz]  
 $-76$  dBc/Hz [ $> 4$  GHz]

### Test signal power:

F  $< 10$  MHz:  $-3$  to  $-20$  dBm  
10 MHz  $< F < 4$  GHz:  $+6$  to  $-20$  dBm  
F  $> 4$  GHz:  $+3$  to  $-20$  dBm

### Power setting resolution:

0.1 dB

### Power setting accuracy:

$\pm 1.5$  dB

### Reference input frequency:

10 MHz  $\pm 6$  ppm

### Reference input level:

0  $\pm 3$  dBm

### Reference output level:

0  $\pm 3$  dBm

## Rear panel connections

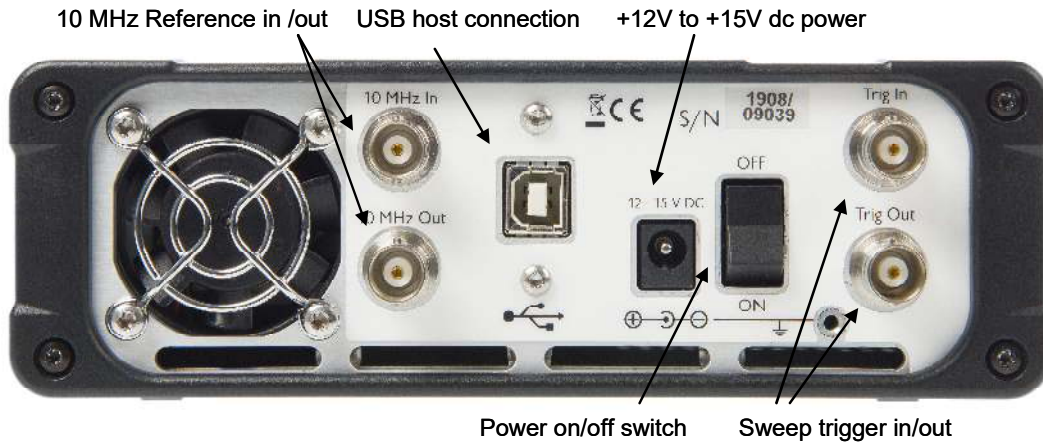

## Miscellaneous

**Controlling PC data interface:**  
USB 2.0

**Support for third party test software:**  
Dynamic Link Library (DLL) as part of user interface software

**External dimensions (mm):**  
286 x 174 x 61 (L x W x H)  
Excluding connectors

**Weight:**  
2.1 kg

**Temperature range (operating):**  
+15 °C to +35 °C

**Temperature range (storage):**  
-20 °C to +50 °C

**Humidity:**  
80% max, non-condensing

**Vibration (storage):**  
0.5G, 5 Hz to 300 Hz

**Power source and current:**  
+12 Vdc to +15 Vdc, 1.6A max

**Power source connector:**  
5.5 mm diameter hole, 2.1 mm diameter centre contact pin. Centre pin is positive.

### Host PC requirements:

MS Windows© XP or later  
2 GB RAM or more  
Screen resolution 1680x1050 or higher



## Ordering information

Check with the factory for availability of the LA19-13-04 and accessories in your country. The prices given may exclude any local taxes and shipping costs. Please contact the factory or your local LA Techniques Ltd representative for more information.

The LA19-13-04 is supplied in a carry case, with the operating software in a CD ROM or USB memory stick and with a universal AC to DC power supply capable of operating with a mains voltage of between 90 VAC and 250 VAC.



### Vector Network Analyzer

Item	Description	GBP
LA19-13-04	VNA, carry case, universal power supply and operating software in a CD ROM (or USB memory stick)	TBD

### Calibration Kits

Item	Description	GBP
DW97157	PC3.5 Female calibration kit including female Short, Open, Load and a female to female adaptor all in a presentation case. Kit data in a CD ROM or USB memory stick.	TBD

Item	Description	GBP
DW97158	PC3.5 Male calibration kit including male Short, Open, Load and a male to male adaptor all in a presentation case. Kit data in a CD ROM or USB memory stick.	TBD

Item	Description	GBP
DW97157 + DW97158	DW97157 and DW97158 in a single presentation case with all kit data in a single CD ROM or USB memory stick	TBD

### Test cables

Item	Description	GBP
VcableSet1	Set of two economy flexible test cable, N (male) to PC3.5 (male), 500 to 600 mm long. Flexing phase stability <math>< 3^\circ</math> at 6 GHz	TBD

Item	Description	GBP
VcableSet2	Set of two precision flexible test cable, N (male) to PC3.5 (male), approximately 600 mm long. Flexing phase stability <math>< 1^\circ</math> at 6 GHz	TBD

### Torque spanner

Item	Description	GBP
TSpan1	Suitable for PC3.5 and SMA connectors	TBD

### Verification device

The DW97194 Iss.4 is an insertable verification device with PC3.5 connectors. It consists of a section of 25Ω transmission line that provides a consistent means of verifying the correct performance of the VNA.



The device is ideal for use with the LA19-13-04's Compare Data utility as quick and easy way of checking the correct operation of the VNA, associated calibration kits and test cables.

Item	Description	GBP
DW97194 Iss.4	Mismatched line verification device supplied with reference factory data including uncertainty values.	TBD

### Post sales calibration

Item	Description	GBP
VNACal	Factory calibration of LA19-13-04 with up to two calibration kits. Calibration certificate, test report and instrument sticky labels.	TBD